

# LEDS & LASER DIODES

Light-emitting diodes or 'LEDs' are now very widely used in almost every area of electronics, mainly as indicator and display devices — in effect, 'solid state lamps'. They're very well suited for such uses, because they are physically quite rugged and hence much more reliable than filament-type incandescent lamps. They also run much cooler and are much more efficient, requiring far less electrical power input for the same amount of light output.

Other common uses for LEDs are as a source of either visible or infra-red light, as a carrier for data and other information over short 'line of sight' distances.

A LED is basically just a specialised type of P-N junction diode, made from a thin chip of fairly heavily doped semiconductor material. When it is forward biased to reduce the potential barrier provided by the junction's narrow depletion layer, electrons from the semiconductor's conduction band can combine with holes from the valence band, releasing sufficient energy to produce photons of light. Because of the thin chip a reasonable number of these photons can leave it and radiate away as its light output.

Unlike diodes made for detection and power rectification, which are generally made from either germanium or silicon, LEDs are made from compound semiconductor materials such as gallium arsenide (GaAs), gallium phosphide (GaP), gallium arsenide-phosphide (GaAsP), silicon carbide (SiC) and gallium indium nitride (GaInN). The exact choice of semiconductor determines the wavelength of peak emission of photons — and hence the colour of the light emitted, in the case of visible light LEDs. It can also determine the electro-optical conversion efficiency, and hence the light output.

Another parameter which is determined by the semiconductor used is the forward voltage drop for a given amount of forward conduction current.

Table I shows the peak emission wavelength for the most common types of LED, with the approximate colour indicated and also the typical forward voltage drop for a forward current of 20mA.

The construction of a typical LED is shown in Fig.1. The semiconductor chip is glued via electrically conductive cement to the inner end of the cathode lead, which is often formed into a tiny dish-shaped reflector to direct as much as possible of the emitted light upward. A small bonding wire is used to connect the anode lead to an electrode deposited on the top of the chip, and the complete assembly is then encapsulated in transparent epoxy resin plastic — either 'water clear', or tinted to match the colour of the LED's peak emission.

Leaded LEDs like that shown are made in a variety of package shapes and sizes, of which the 3mm and 5mm

Semiconductor material	Peak Emission wavelength	Approximate Colour	V <sub>F</sub> @ 20mA
GaAs	910nm	(Infra-red)	1.2V
GaAsP	650-710nm	Amber-Red	2.0V
GaAsP:N	580-620nm	Yellow	2.1 - 2.2V
GaP	560nm	Green	3.5V
SiC	413-560nm	Blue	3.6V
GaInN	460 +570nm	White	3.6 - 4.0V

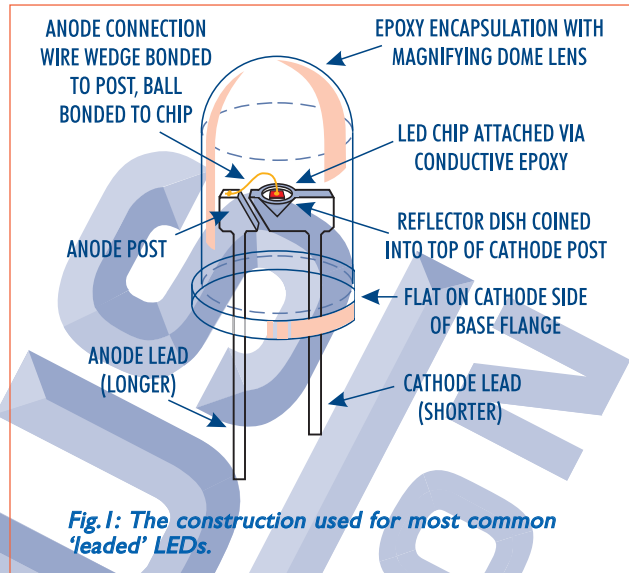
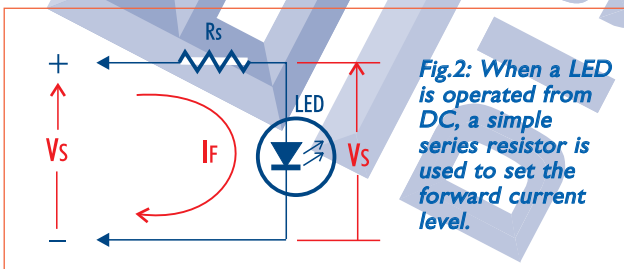

diameter 'bullet' type with a spherical front lens are the most common. Other much smaller packages are used for surface-mount LEDs, including 'naked' LED chips.

In most cases LEDs are operated from a low voltage DC supply, with a series resistor (Fig.2) to limit the forward current to a suitable value — from say 5-6mA for a simple pilot lamp or status indicator application to 20mA or more where more light output is needed. The series resistor value  $R_s$  is calculated using Ohm's law, knowing the required operating current  $I_F$ , the supply voltage  $V_s$  and the expected forward voltage drop of the LED at this current level,  $V_F$ :

$$R_s = (V_s - V_F) / I_F$$

The LED's forward voltage drop  $V_F$  can usually be estimated from the figure usually given in the data books for a current of 20mA, although the actual voltage drop will be a bit lower for very low current levels. LEDs are intended to operate *only* in forward conduction mode, and should not be subjected to reverse voltage. In most cases they have a reverse voltage rating of 5V or even less, so they can be damaged by accidental reverse connection at even quite low supply voltages. If the LED

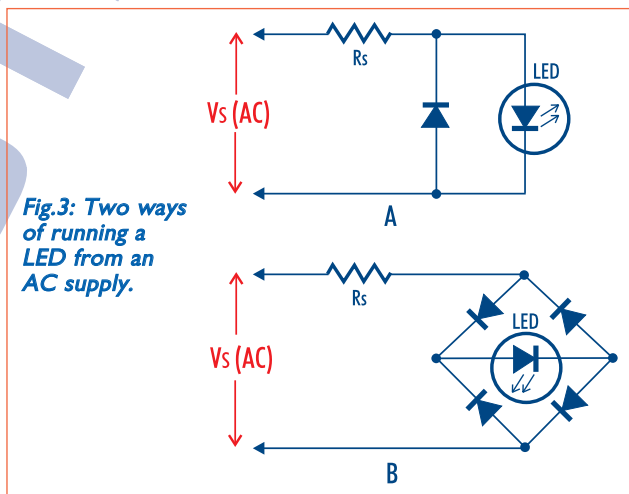

## Electus Distribution Reference Data Sheet: LEDLASER.PDF (2)

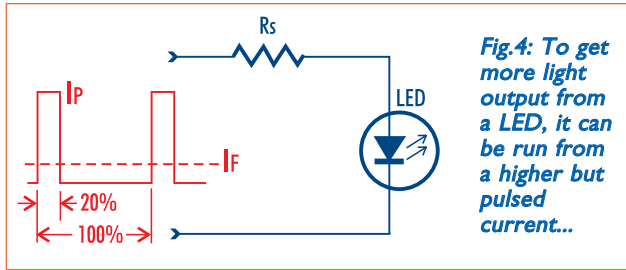

needs to be operated from an AC supply, or from a signal source which cannot be relied upon not to reverse its polarity, it can be protected by one of the methods shown in Fig.3. The simplest approach is shown in A, where a reverse connected silicon diode is connected directly across the LED to limit any reverse voltage to 0.6V. This protects the LED, but of course no light is emitted for the negative half-cycles of the AC waveform — even though current is still drawn from the supply. So the light output and efficiency are both effectively halved.

The alternate method shown in B is more efficient, and also maintains the LED light output. Here a bridge of four diodes is used to ensure that the current always flows through the LED in the forward direction, regardless of supply polarity. (Note that the voltage drop of two diodes — about 1.2V — needs to be taken into account when the value of  $R_s$  is being calculated.)

The maximum light output from a LED (usually measured and rated in **millicandelas**) is essentially limited by the maximum average forward current which it can handle, which is determined mainly by the LED chip's power dissipation rating — typically less than 100mW, for plastic encapsulated devices.

When higher light output is required, the usual approach is to operate the LED not from a steady DC supply, but from a pulsed current with a fairly short duty cycle (on-off ratio). This allows the current and hence the light output to be increased significantly during the actual pulses, while still keeping the LED's average current level and power dissipation within its ratings (Fig.4).

Why does this pulsed output give an advantage? Partly because the electro-optical efficiency of LEDs actually tends

to increase with current level. So short pulses of significantly higher output separated by periods of no output actually result in a higher average light output, for the same average current.

In addition, the human eye's persistence of vision tends to 'fill in the gaps' between the light pulses, providing the pulse repetition frequency is significantly higher than the eye's critical fusion frequency (CFF). So pulses at a frequency of 100Hz or more actually appear brighter than continuous light of the same average intensity.

A simple low cost pulse generator using a 555 or similar device can be used to produce pulses with a duty cycle of say 20%, and can be used to drive the LED either directly or via a power MOSFET. Either way a series resistor is again used to limit the LED current — but in this case to the right peak value (say 100mA, for a 20% duty cycle).

### Laser diodes

Laser diodes (also called 'injection lasers') are in effect a specialised form of LED. Just like a LED, they're a form of P-N junction diode with a thin depletion layer where electrons and holes collide to create light photons, when the diode is forward biased.

The difference is that in this case the 'active' part of the depletion layer (i.e., where most of the current flows) is made quite narrow, to concentrate the carriers. The ends

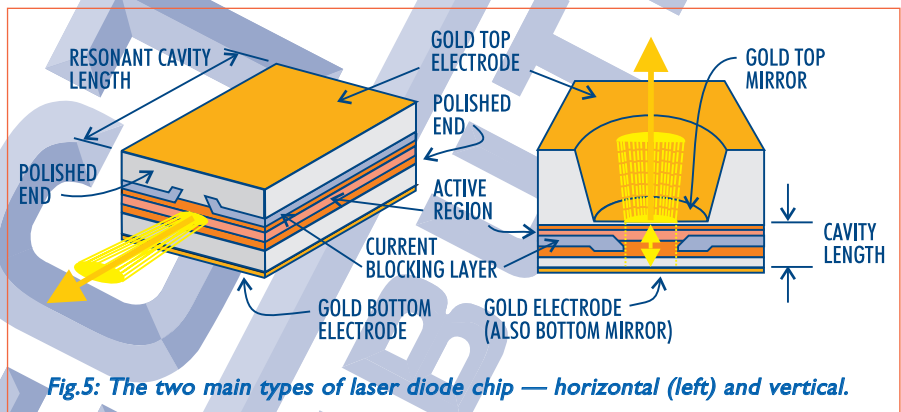

of this narrow active region are also highly polished, or coated with multiple very thin reflective layers to act as mirrors, so it forms a resonant **optical cavity**.

The forward current level is also increased, to the point where the current density reaches a critical level where 'carrier population inversion' occurs. This means there are more holes than electrons in the conduction band, and more electrons than holes in the valence band — or in other words, a very large excess population of electrons and holes which can potentially combine to release photons. And when this happens, the creation of new photons can be triggered not just by random collisions of electrons and holes, but also by the influence of passing photons.

Passing photons are then able to stimulate the production of more photons, without themselves being absorbed. So laser action is able to occur: **Light Amplification by Stimulated Emission of Radiation**. And the important thing to realise is that the photons that are triggered by other passing photons have the same wavelength, and are also in phase with them. In other words, they end up 'in sync' and forming continuous-wave **coherent radiation**.

Because of the resonant cavity, photons are thus able to travel back and forth from one end of the active region to the other, triggering the production of more and more photons in sync with themselves. So quite a lot of coherent light energy is generated.

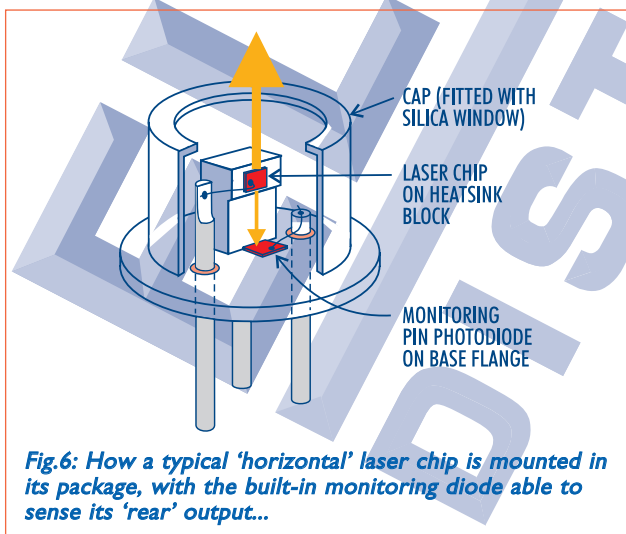

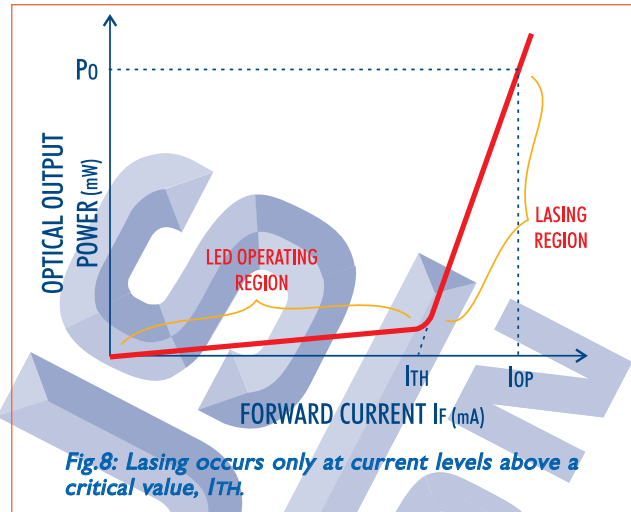
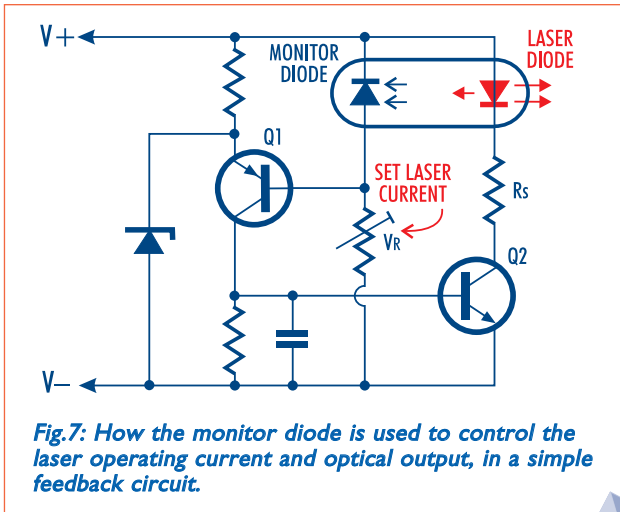

And as the ends of the cavity are not *totally* reflective (typically about 90-95%), some of this coherent light can leave the laser chip — to form its output beam. Because a laser's light output is coherent, it is very low in noise and also more suitable for use as a 'carrier' for data communications. The bandwidth also tends to be narrower and better defined than LEDs, making them more suitable for optical systems where light beams need to be separated or manipulated on the basis of wavelength.

The very compact size of laser diodes makes them very suitable for use in equipment like CD, DVD and MiniDisc players and recorders. As their light is reasonably well collimated (although not as well as gas lasers) and easily focussed, they're also used in optical levels, compact hand-held laser pointers, barcode scanners etc.

There are two main forms of laser diode: the horizontal type, which emits light from the polished ends of the chip, and the vertical or 'surface emitting' type. They both operate in the way just described, differing mainly in terms of the way the active light generating region and resonant cavity are formed inside the chip. (See Fig.5)

Because laser diodes have to be operated at such a high current density, and have a very low forward resistance when lasing action occurs, they are at risk of destroying themselves due to thermal runaway. Their operating light density can also rise to a level where the end mirrors can begin melting. As a result their electrical operation must be much more carefully controlled than a LED.

This means that not only must a laser diode's current be regulated by a 'constant current' circuit rather than a simple series resistor, but *optical negative feedback* must generally be used as well — to ensure that the optical output is held to a constant safe level.

To make this optical feedback easier, most laser diodes have a silicon PIN photodiode built right into the package, arranged so that it automatically receives a fixed proportion of the laser's output. The output of this *monitor diode* can then be used to control the current fed through the laser by the constant current circuit, for stable and reliable operation.

Fig.6 shows a typical 'horizontal' type laser chip mounted in its package, with the monitor photodiode mounted on the base flange below it so the diode receives the light output from the 'rear' of the laser chip.

Fig.7 (page 3) shows a simple current regulator circuit used to operate a small laser diode, and you can see how the monitor photodiode is connected. The monitor diode is shunting the base forward bias for transistor Q1, which has its emitter voltage fixed by the zener diode. So as the laser

output rises, the monitor diode current increases, reducing the conduction of Q1 and hence that of transistor Q2, which controls the laser current. As a result, the laser current is automatically stabilised to a level set by adjustable resistor VR.

### Laser diode parameters

Perhaps the key parameter for a laser diode is the **threshold current** ( $I_{TH}$ ), which is the forward current level where lasing actually begins to occur. Below that current level the device delivers some light output, but it operates only as a LED rather than a laser. So the light it does produce in this mode is *incoherent*.

Another important parameter is the **rated light output** ( $P_0$ ), which is the highest recommended light output level (in milliwatts) for reliable continuous operation. Not surprisingly there's an **operating current level** ( $I_{OP}$ ) which corresponds to this rated light output (Fig.8). There's also the corresponding current output from the feedback photodiode, known as the **monitor current level** ( $I_m$ ).

Other parameters usually given for a laser diode are its **peak lasing wavelength**, using given in *nanometres* (nm); and its **beam divergence angles** (defined as the angle away from the beam axis before the light intensity drops to 50%), in the X and Y directions (parallel to, and normal to the chip plane).

### Laser safety

Although most of the laser diodes used in electronic equipment have quite low optical output levels — typically less than 5mW (milliwatts) — their output is generally concentrated in a relatively narrow beam. This means that it is still capable of causing damage to a human or animal eye, and particularly to its light-sensitive *retina*.

Infra-red (IR) lasers are especially capable of causing eye damage, because their light is not visible. This prevents the eye's usual protective reflex mechanisms (iris contraction, eyelid closure) from operating.

So always take special care when using devices like laser pointers, and especially when working on equipment which includes IR lasers, to make sure that the laser beam cannot enter either your own, or anyone else's eyes. If you need to observe the output from a laser, either use protective filter goggles or use an IR-sensitive CCD type video camera. Remember that eye damage is often irreversible, especially when it's damage to the retina.

(Copyright © 2001, Electus Distribution)